

Installation and commissioning instructions

MDC0014-04

For Mixergy PV switch

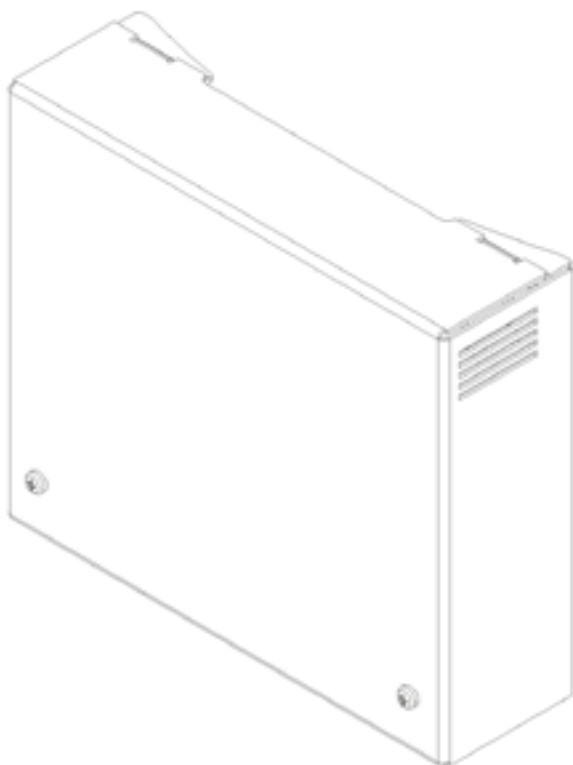

mixergy

About this module

The Mixergy PV switch is an intermediary relay device which allows for external 3rd party PV diverters to be integrated with the Mixergy cylinder and share use of the primary immersion.

Under idle conditions, control of the immersion is given to the PV diverter. Whenever the Mixergy controller calls for heat through the immersion via. boost or a scheduled heating event, control of the immersion is switched away from the PV diverter and given to the Mixergy controller.

For all queries, please contact us:

Tel: 01865 884343

Email: enquiries@mixergy.co.uk

Technical data

Supported (input) diverter(s)	1
Supported (output) immersion(s)	1
Supported immersion rating	230-240 V~ 2.7-3.0 kW
Supported immersion specification	EN 60335-2-73
Max. idle consumption (12V)	250 mW
Max. active consumption (12V)	1500 mW

Contents

About this module	2
Technical data	2
Contents	3
Included items	4
Installation: general guidelines	4
Installation: mechanical	5
Installation: electrical	6
Installation: commissioning	8
Troubleshooting	8
Replacement parts	9

Included items

- MAS0086-01 PV ready switch box complete
- MEL0049 2m pump cable extension
- 2x MME0077 Screw No 8 x 13mm Self Drilling
- 2x MME0152 Plastic spacer
- Installation guide

Installation: general guidelines



ENSURE ALL ELECTRICAL SUPPLIES ARE SWITCHED OFF BEFORE MAKING ANY CONNECTION TO THE UNIT. ELECTRICAL INSTALLATION MUST BE CARRIED OUT BY COMPETENT ELECTRICIAN AND BE IN ACCORDANCE WITH THE LATEST I.E.E. REGULATIONS.



Ensure that all mains cabling used has a minimum CSA of 1.5 mm² with a minimum temperature rating of 90C (H05V2V2-F).

Avoid fitting the PV switch or making electrical junctions directly underneath water pipework.

The PV switch can be fixed to the outer wrapper of the cylinder using the two self drilling screws or to an adjacent wall using the provided plastic spacers. In the case of a wall-mount, the immersion cable will need to be extended. Ensure that the junction used to perform this extension has a minimum IP41 rating and is appropriately rated to handle 240V~ 13A continuous.

Installation: mechanical

1. Remove the front cover of the PV switch.
2. Mount the PV switch either to the side wall of the cylinder (using the included self-drilling screws) or to a nearby wall (using the included plastic spacers).
3. Remove the cover/cap on the primary immersion heater.

1

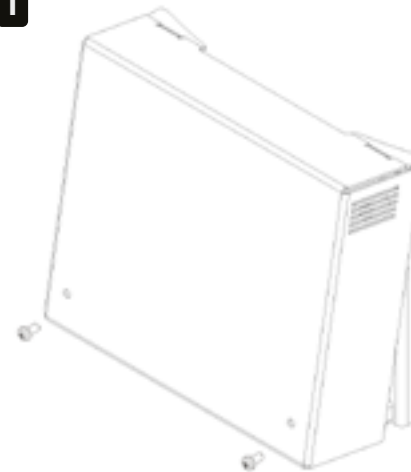

2



3



3 (SLIM)



Installation: electrical

4. Disconnect the existing wiring to the immersion heater. Connect these wires to terminals MXL(L), MXN(N), GND(E) on the PV switch. This cable can be extended using 1.5mm² CSA 3-core H05V2V2-F flex if required.
5. Connect the third party PV diverter output to terminals PVL(L), PVN(N), GND(E) on the PV switch using 1.5mm² CSA 3-core H05V2V2-F flex.
6. Connect the immersion heater to PV switch terminals IML(L), IMN(N), GND(E) using 1.5mm² CSA 3-core H05V2V2-F flex.

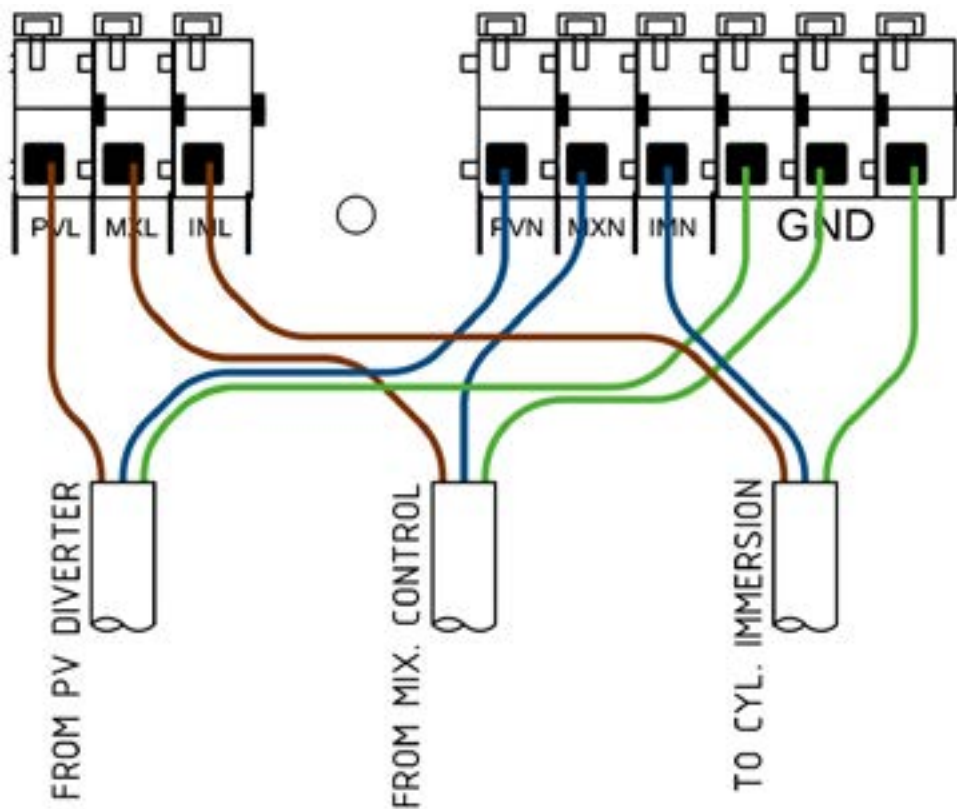

Installation: electrical

7. Remove the Mixergy cylinder controller's top cover by unscrewing the screws as shown opposite and pulling the cover away.
8. Unplug the pump cable (white 3 pole connector at the bottom right of the controller circuit board) from the cylinder controller. Connect one end of the supplied pump extension cable in its place. Connect the other end of the pump extension cable to one of the two PUMP connectors on the PV switch.
9. Connect the cable from the Mixergy pump to the remaining PUMP connector on the PV switch.
10. Adjust the immersion thermostat to approx. 65 C. For thermostats without discrete temperature steps, move the dial to the 3/4 of max position. Note that this may need to be adjusted after the system has been tested.
11. Replace immersion cover, PV switch cover and cylinder controller cover.

7

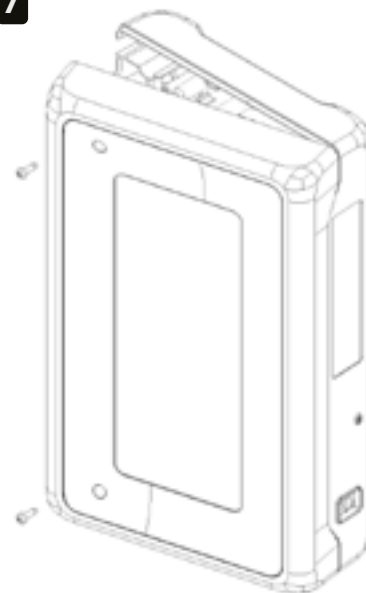

7 (alt)

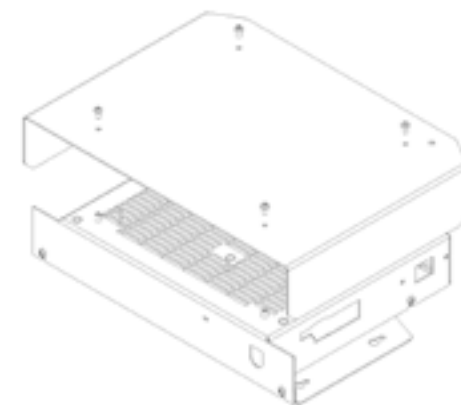

Installation: commissioning

1. Restore power to external diverter and Mixergy controller
2. Cancel and scheduled heating events/boosts from the Mixergy controller (if active).
3. Set the PV diverter to bypass/boost and check that the immersion is heating via the diverter.
4. Set the Mixergy controller heat source to electric and boost using the gauge, observe that the bypass/boost function of the diverter is switched off and the cylinder continues to heat via. the Mixergy controller supply.
5. Set the exchanger circulator pump speed to setting II for heat pumps, I for solar thermal.

Troubleshooting

Diverter not working correctly

If the diverter is unable to supply heat to the cylinder, perform the following checks:

- Check that the cylinder is not entirely full of hot water (i.e. 100% charged). If the cylinder is full of hot water, drain the cylinder down 20-30% and repeat the commissioning steps.
- Check that the cylinder immersion thermostat is adjusted to its maximum set temperature.
- Check that the diverter is setup correctly according to manufacturer's instructions.

RCD tripping

If an RCD is tripping when the cylinder is switched on, double check all mains wiring to the PV switch, diverter and cylinder immersion.

Electrical fault

If an electrical fault of the controller is suspected or the electrical system does not operate as expected, please contact Mixergy directly.

Replacement parts

Do not attempt to repair or replace any parts of the Mixergy cylinder unless you are a trained operative.

If you suspect a fault or a replacement part is needed, please contact Mixergy directly.

Part description	Part no.
PV Switch PCBA	MAS0085
PV Switch enclosure lid	MME0144
Pump cable extension	MAS0090

For more information on our
hot water tanks,
visit us at **[mixergy.co.uk](https://www.mixergy.co.uk)**
email us at **enquiries@mixergy.co.uk**
or call us on **01865 884 343**

mixergy

Mixergy Ltd, 2 Canal View, Wharf Farm,
Eynsham Road, Cassington, Oxfordshire OX29 4DB

T: 01865 884 343 | www.mixergy.co.uk

MIXERGY INSTALLATION AND COMMISSIONING GUIDE MDC0014-04